

# PORTE-OUTILS POUR TENONNEUSE ARRONDISANTE

## TRC10

Composé d'un décheteur Z=3+3+3 et d'un porte-outils Z=3+3 avec pivot cylindrique D. 20 mm.

Il permet l'usinage de tenons de 7 à 30 mm de longueur.

Pour tenonneuse double et centres usinage CN.

Rotation à droite ou à gauche.

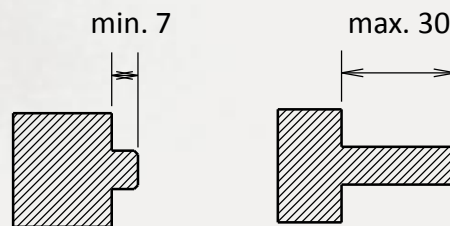
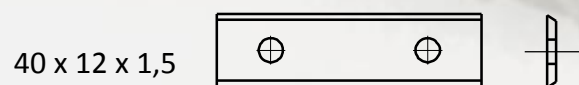
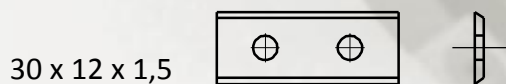
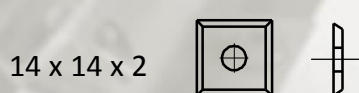
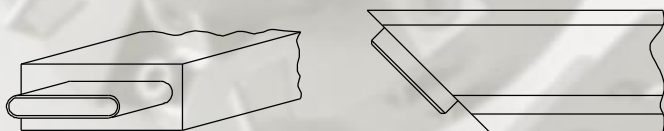
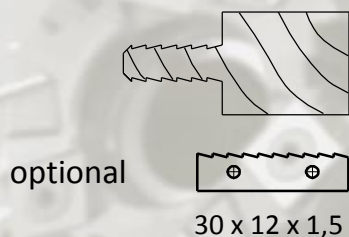
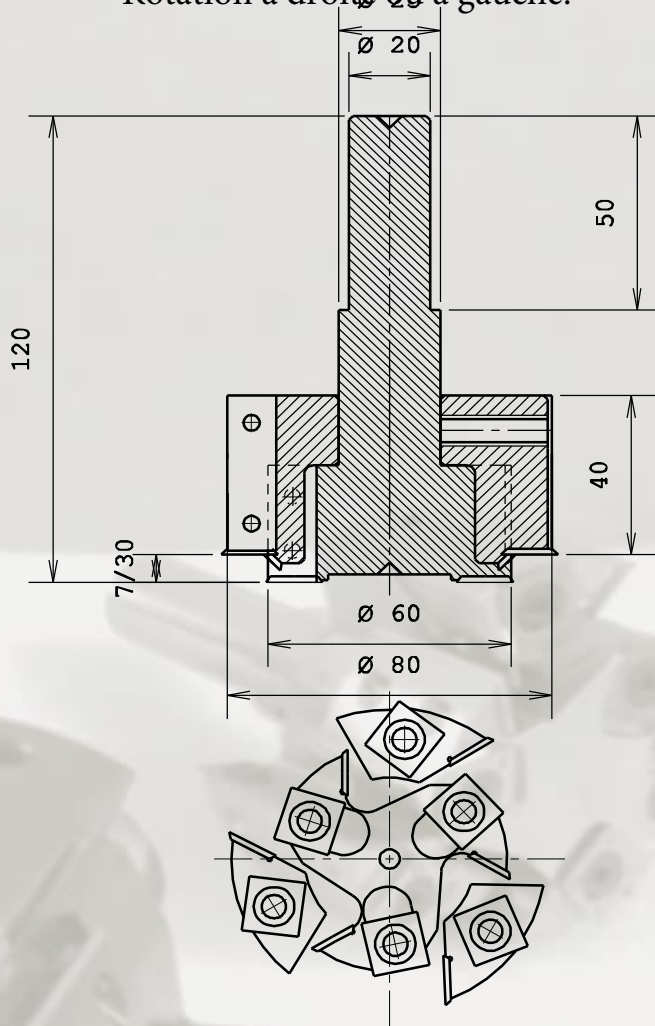

	D.	d.	h.	Z	Tours Max	Code
Porte-outils	60	20	30	3+3	9000	TRC10
Décheteur	80	25	40	3+3+3	9000	