

CUTTERHEADS FOR ROUNDING TENONING MACHINE

TRC2

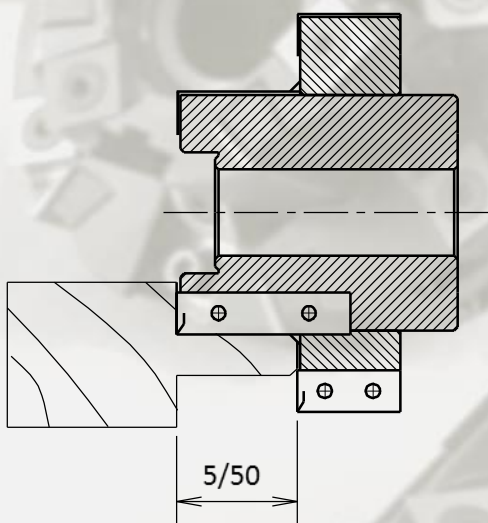

Consisting of a hogger $Z = 6 + 3 + 3$ gleaners with reversible knives to throw a cutter head and $Z = 3 + 3$.
It allows processing of tenons with lengths from 5 to 50 mm.
For double tenoning.
Left or right rotation.

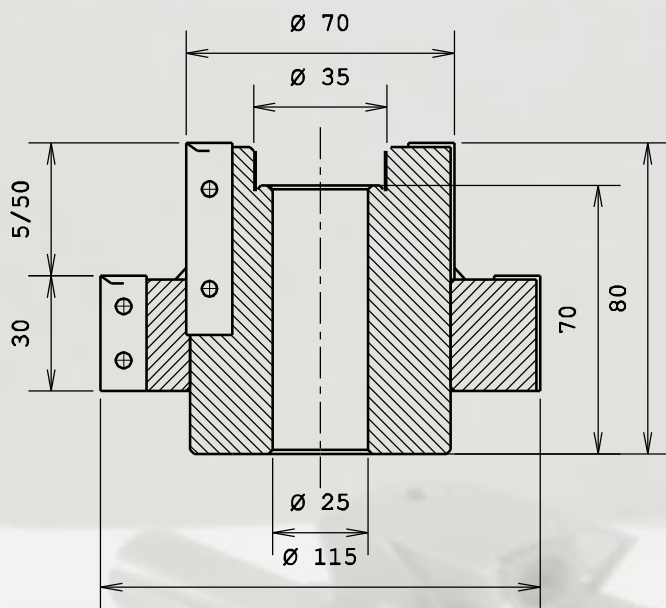

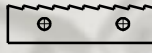
optional 
50 x 12 x 1,5

sp-trc



14 x 14 x 2



30 x 12 x 1,5

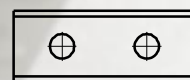

50 x 12 x 1,5

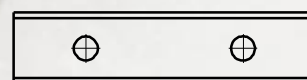

	D.	d.	h.	Z	Max turns	Cod.
Cutterheads	70	25	80	3+3	9000	TRC2
Hogger	115	68,5	30	6+3+3	9000	