

CUTTER HEAD FOR ROUNDING TENONING MACHINE

TRC10

Consisting of a hogger $Z=3+3+3$ and a cutter head $Z=3+3$ with cylindrical sank $D. 20 \text{ mm}$.

It allows processing of tenons with lengths from 7 to 30 mm.

For double tenoning and CN work centers. Left or right rotation.

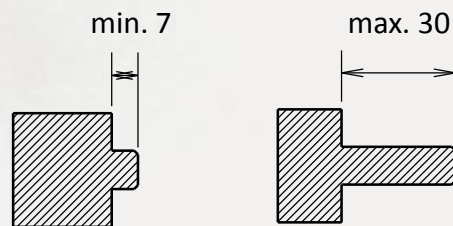
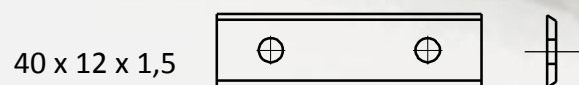
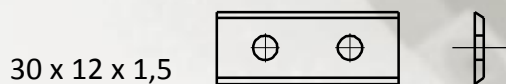
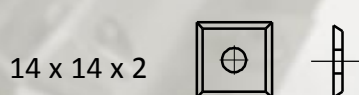
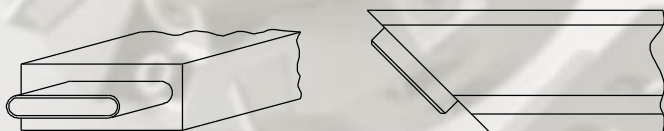
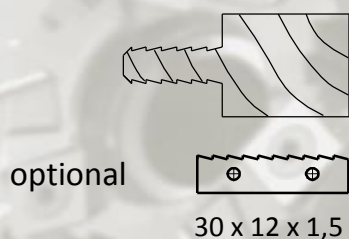
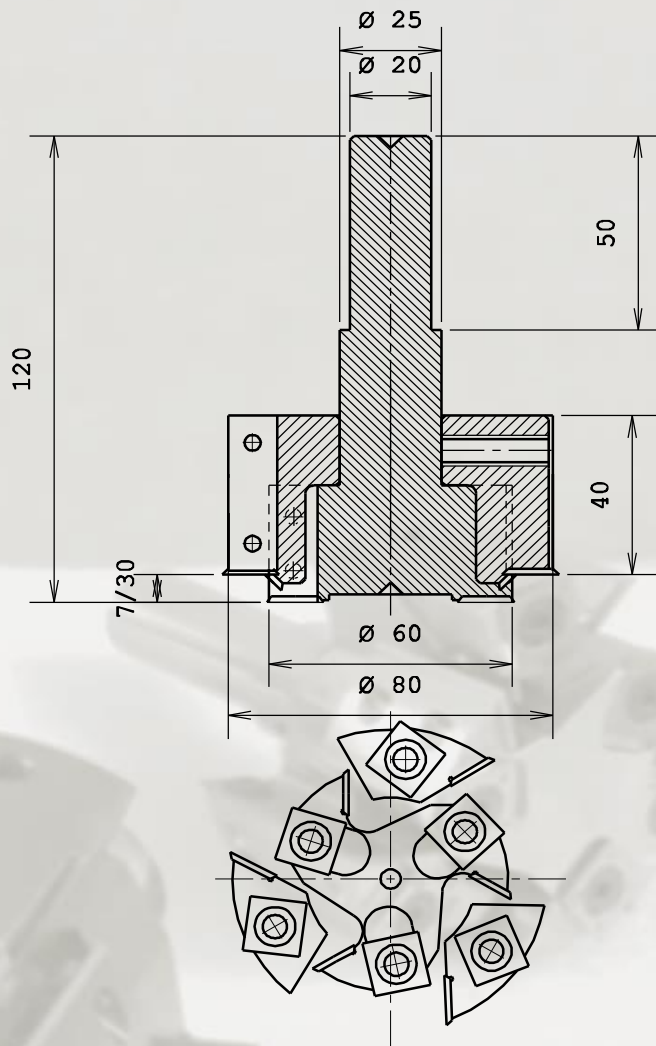

	D.	d.	h.	Z	Max Turns	Code
Cutter head	60	20	30	3+3	9000	TRC10
Hogger	80	25	40	3+3+3	9000	