

# ADJUSTABLE MULTIRADIUS MILL

# FRM

Built with interchangeable blades carbide, it allows simultaneous contouring and lacing panels of different thicknesses and radii on work centers.

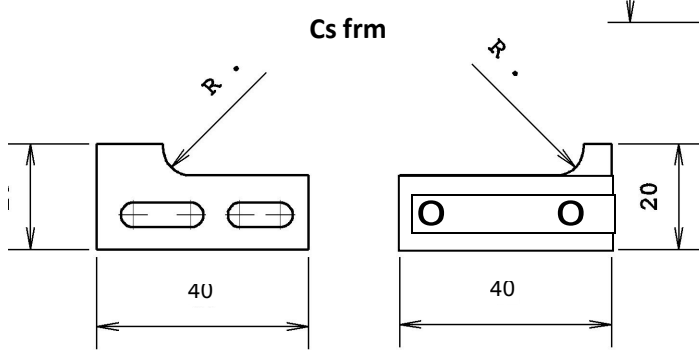
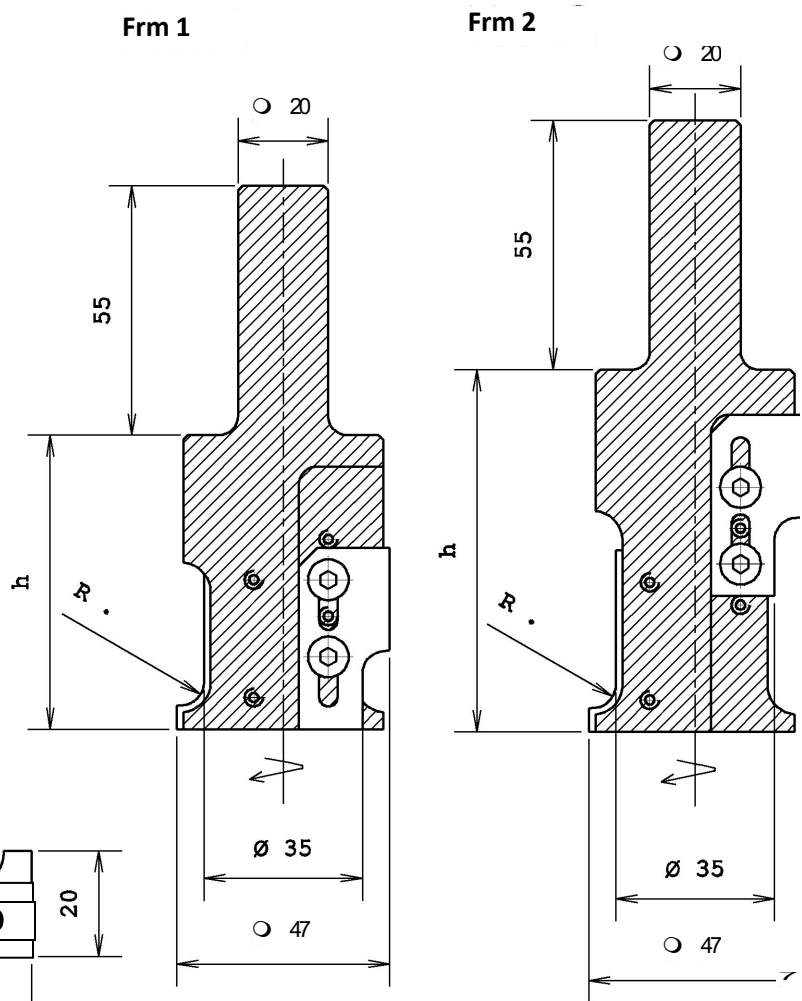

Variable Radii from R=2 to R=5

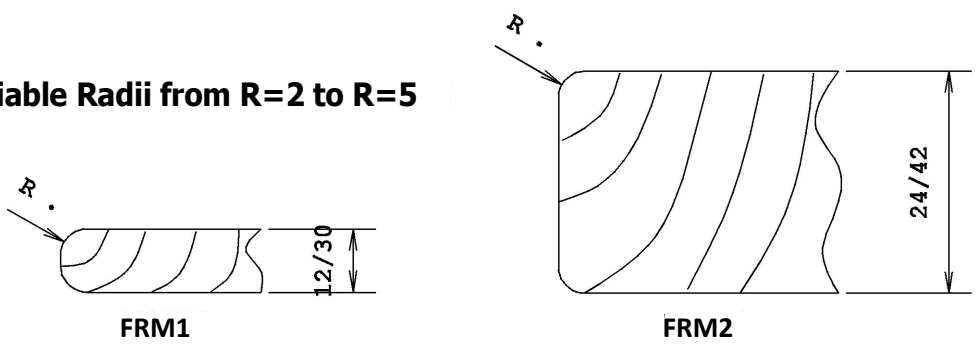

	D.	d.	h.	Z	Max Turns	Code
Frm1	47	20	80	1+1	16.000	<b>FRM</b>
Frm2	47	20	65	1+1	16.000	